

# Finisher-K1/K2 Installation Procedure

Follow the instructions in this booklet when installing the Finisher-K1/K2 to a copier.

1	Selecting the Site
---	--------------------

Select the site of installation, making sure that there will be adequate space for copying work (e.g., removing copies). Be sure to avoid areas where the floor will not keep the finisher level with the copier (with steps, slopes, different materials).

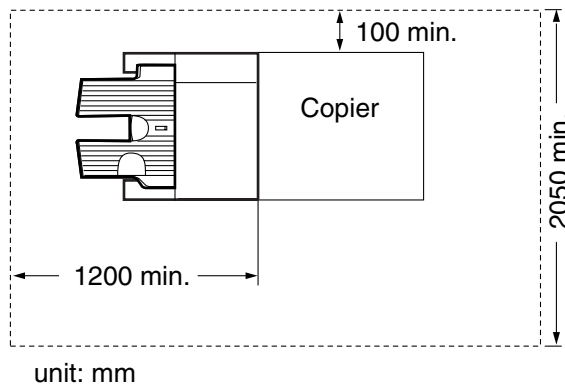


Figure 1-1

**Note1:**

⚠ If you are installing the Side Paper Deck-M1 together with the finisher, be sure to install the side paper deck first.

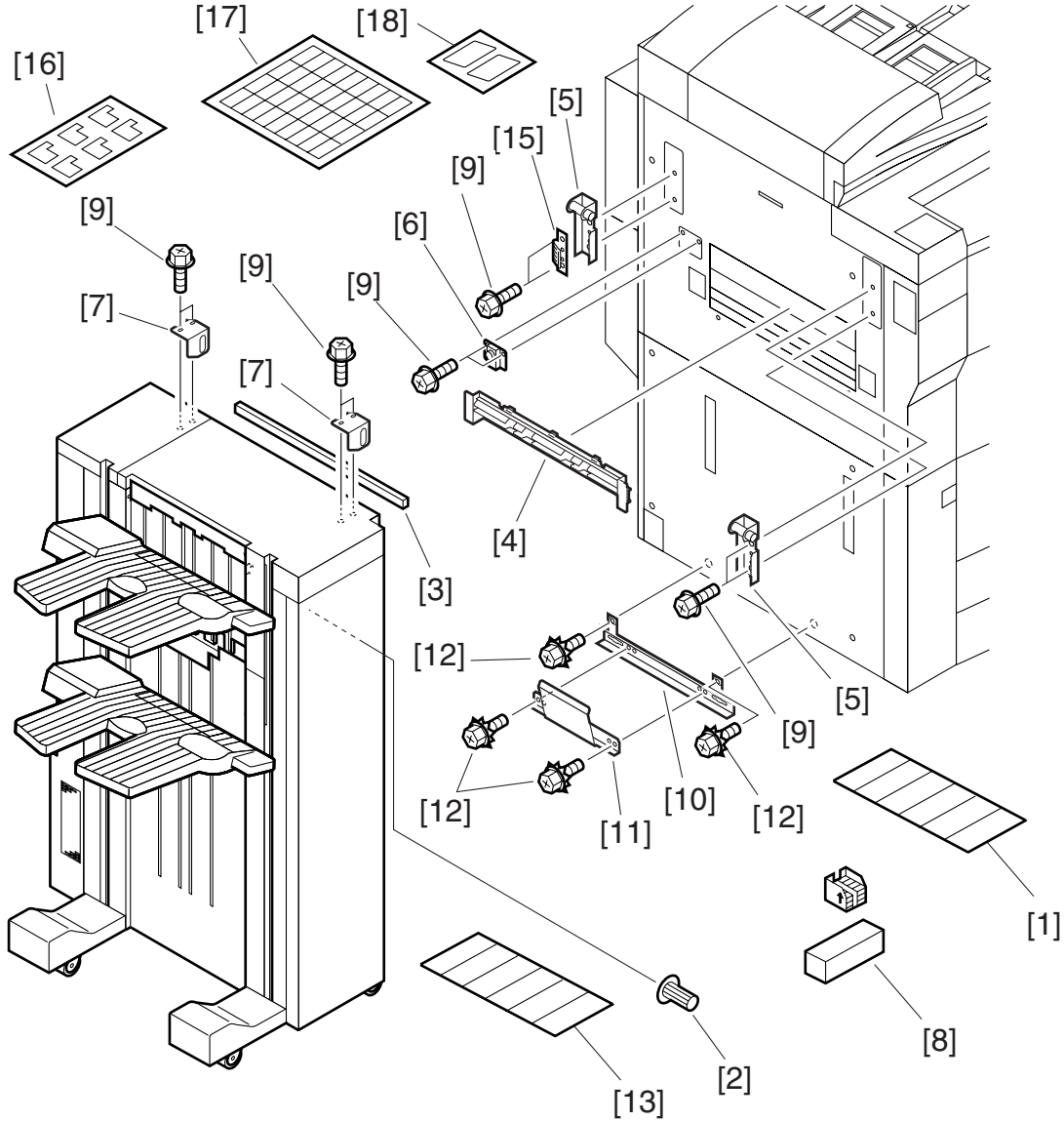
**Note2:**

⚠ You will need to deal with the grounding spring in either of the following three ways depending on how the Side Paper Deck-M1 is installed; perform the appropriate steps:

1. The Side Paper Deck-M1 has not been installed;
2. The Side Paper Deck-M1 will be installed together with the Finisher-M1 (in this case, install the paper deck first); or
3. The Side Paper Deck-M1 has been installed.

2	Unpacking
---	-----------

Unpack the shipping box of the finisher, and check to make sure that none of the parts shown in Figure 2-1 is missing:



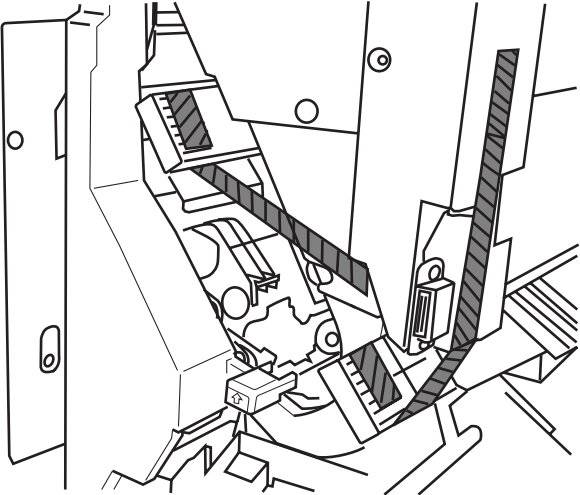
- |   |  |
|---|--|
| [1] Punch position Label ..... 1 pc.      | [10] Spring mounting plate ..... 1 pc.   |
| [2] Buffer roller knob ..... 1 pc.        | [11] Grounding spring 1 ..... 1 pc.      |
| [3] Upper cover spacer ..... 1 pc.        | [12] RS tightening screw                 |
| [4] Inlet guide ..... 1 pc.               | (M4x8; w/ washer; white) ..... 4 pc.     |
| [5] Latch plate ..... 2 pc.               | [13] Paper turning label ..... 1 pc.     |
| [6] Positioning pin ..... 1 pc.           | [15] Grounding spring 2 ..... 1 pc.      |
| [7] Latch fixing plate ..... 2 pc.        | [16] Module separation label ..... 1 pc. |
| [8] Staple cartridge ..... 1 box (3 pc.)  | [17] Setting label ..... 1 pc.           |
| [9] RS tightening screw                   | [18] Tray label ..... 1 pc.              |
| (M4x10; white; round tipped) ..... 10 pc. |  |

Figure 2-1

<b>3</b>	<b>Packing Materials Inside the Finisher</b>
----------	--

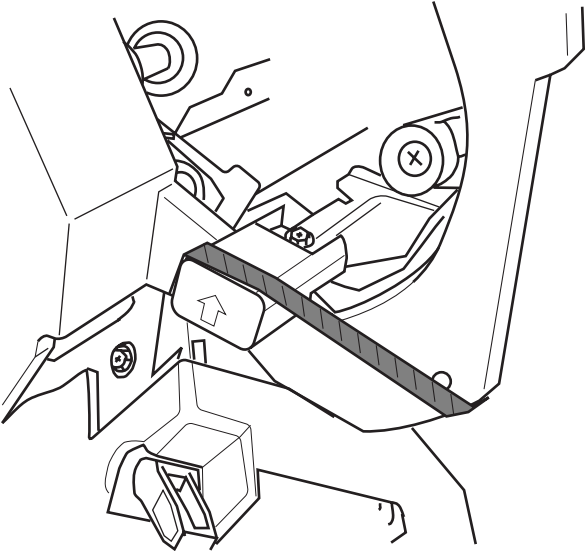
Figures 3-1 through -3 show the locations of packing materials used inside the finisher. Locate and remove them.

Near the Inlet Guide



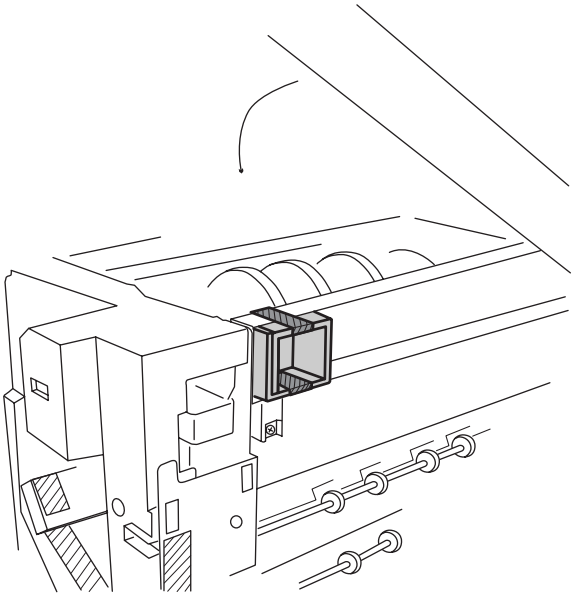
**Figure 3-1**

Near the Feeding Guide



**Figure 3-2**

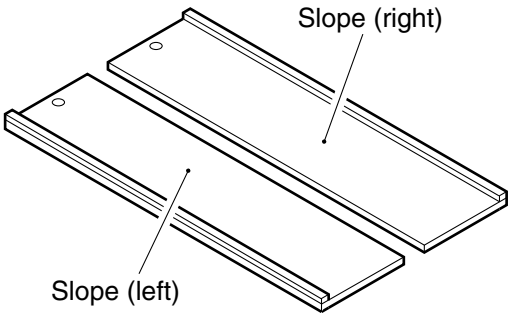
Near the upper right corner.



**Figure 3-3**

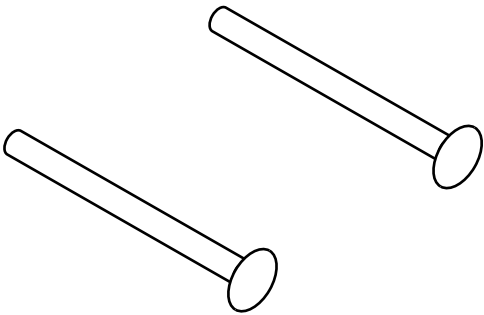
<b>4</b>	<b>Moving off the Pallet</b>
----------	------------------------------

1) Take out the two slopes from the pallet.



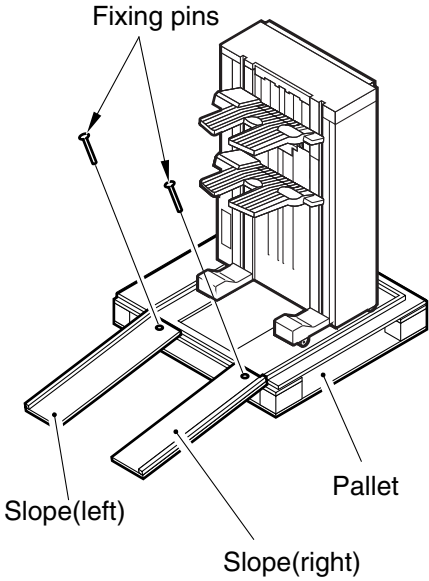
**Figure 4-1**

2) Take out the two fixing pins from the slope.



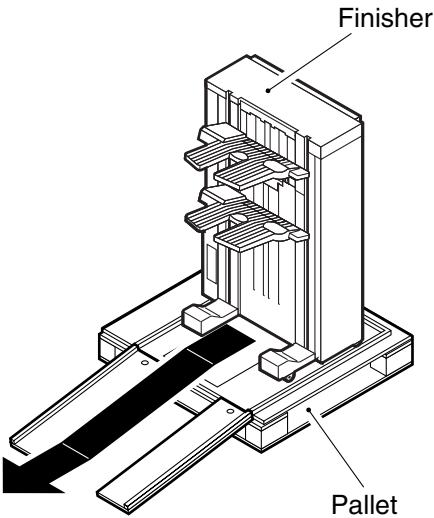
**Figure 4-2**

3) Secure the slopes to the pallet with two fixing pins. (The two slopes are not alike; use the left slope on the left and the right slope on the right.)



**Figure 4-3**

4) Move the finisher from the pallet along the slopes.



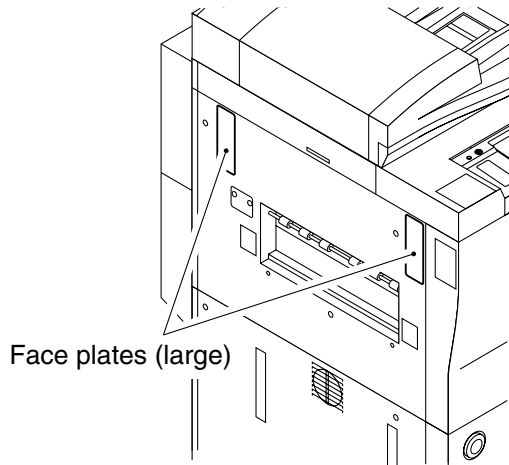
**Figure 4-4**

## 5

## Fitting the Copier Attachments

- 1) Remove the two face plates (large) from the copier's left cover. (You will not be using the removed face plates.)

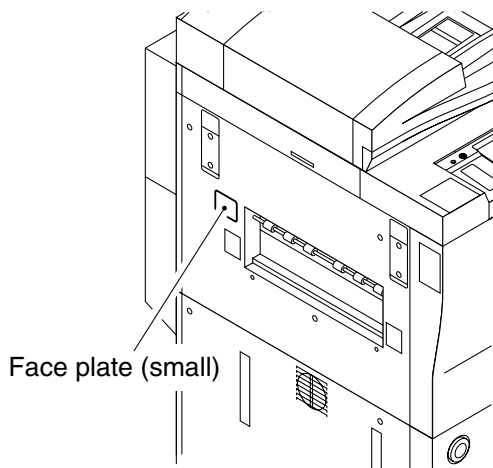
Depending on the time a machine was manufactured, face plates (large) are not attached to the machine.



**Figure 5-1**

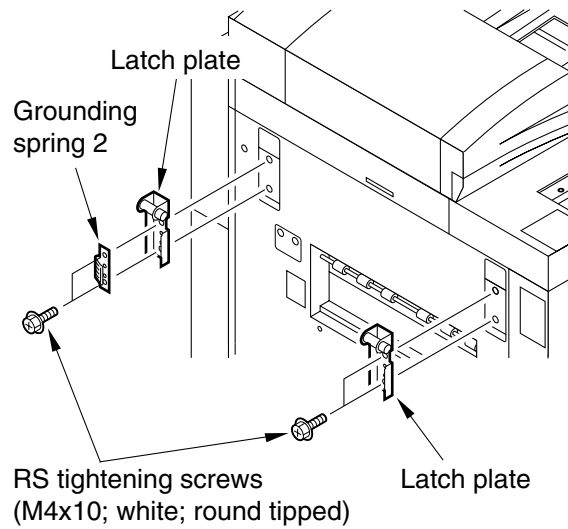
- 2) Remove the face plate (small) from the copier's left cover. (You will not be using the removed face plate.)

Depending on the time a machine was manufactured, face plate (small) is not attached to the machine.



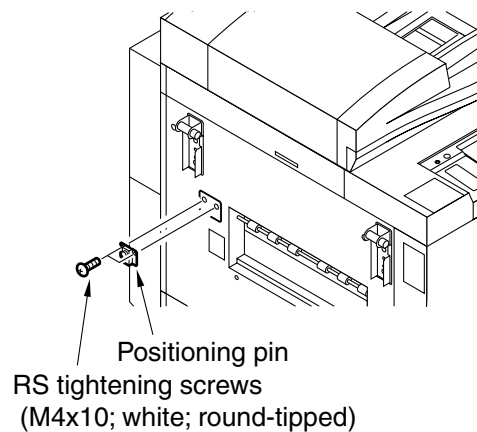
**Figure 5-2**

- 3) Mount the latch plate and the grounding spring 2 to where you have removed the face plates (large) with two RS tightening screws each (M4x10; white; round-tipped).



**Figure 5-3**

- 4) Mount the positioning pin to where you have removed the face plate (small) with two RS tightening screws (M4x10; white; round-tipped).



**Figure 5-4**

- 5) Fit the inlet guide to the copier's left cover, and slide it to the right.

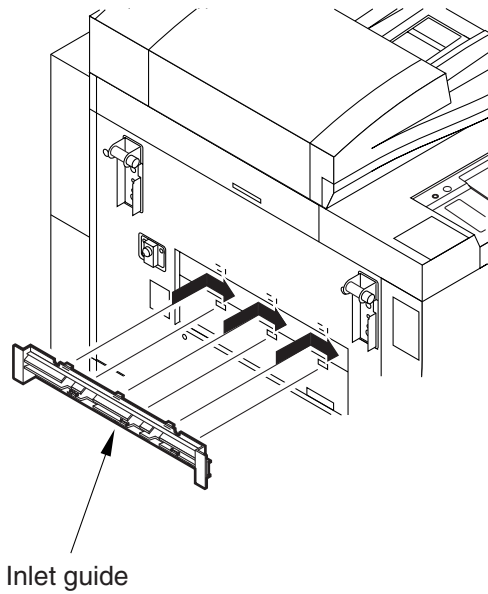


Figure 5-5

5'	Attaching the punch position Label
----	------------------------------------

**Caution:**

⚠ This step applies to the Finisher-K2 only.

- 1) Open the finisher upper cover.
- 2) Attach the Punch position label to the side of the buffer roller as indicated in the figure. Of the seven labels, the topmost label is intended for a 208V model (2/3-hole model). Select the appropriate label from the remaining six to suit the desired language. (There is a label positioning guide.)

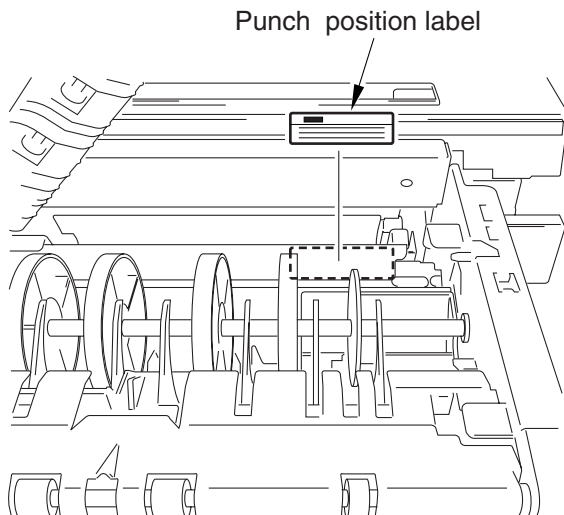


Figure 5'-1

6	Mounting the Grounding Spring
---	-------------------------------

The grounding spring must be mounted in one of three ways according to how the Side Paper Deck-M1 is installed; i.e.,

- a. The Side Paper Deck-M1 is not installed.
  - b. The Side Paper Deck-M1 is to be installed together with the finisher.
  - c. The Side Paper Deck-M1 is already installed.
- 1) If the Side Paper Deck-M1 is not installed, Remove the grip face covers (front, rear), and shift up the front and rear grips as shown.

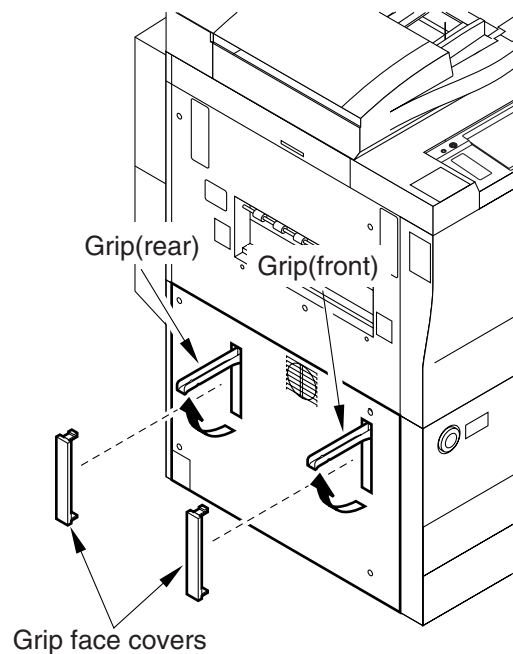
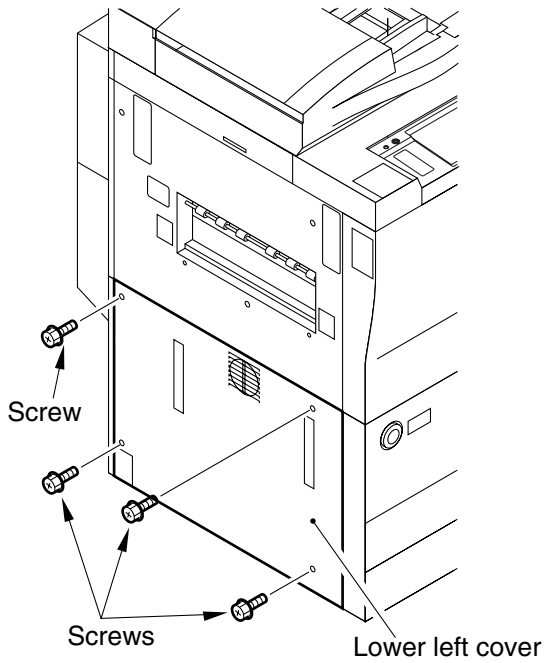


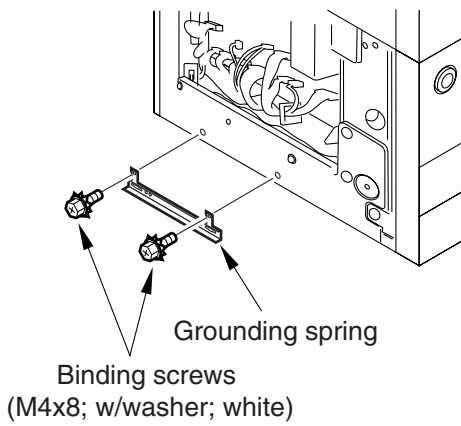
Figure 6a-1

- 2) Remove the four screws, and detach the copier's lower left cover.



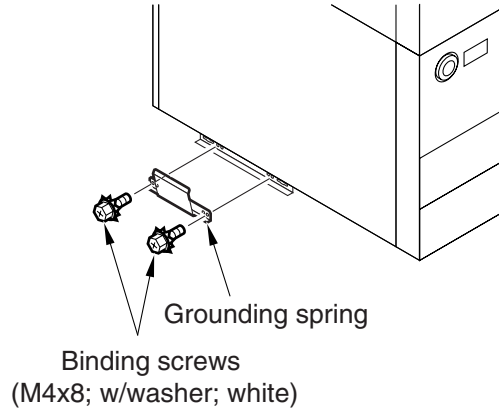
**Figure 6a-2**

- 3) Mount the spring mount to the copier's lower left cross member with two RS tightening screws (w/ washer; M4x8; white).



**Figure 6a-3**

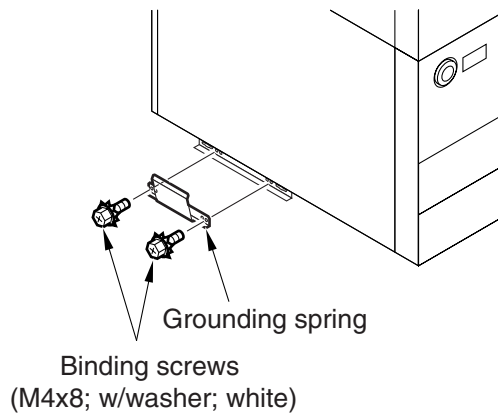
- 4) Mount the copier's lower left cover and the grip face covers with four screws.
- 5) Mount the grounding spring to the spring mount with two RS tightening screws (w/ washer; M4x8; white).



**Figure 6a-4**

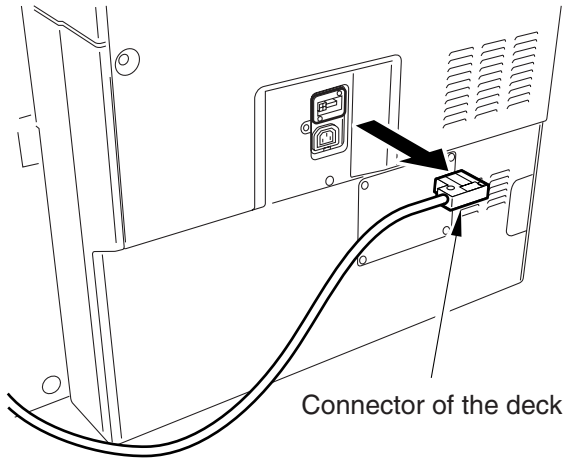
- b. If the Side Paper Deck-M1 is to be installed together with the finisher,

- 1) Mount the grounding spring to the spring mount with two RS tightening screws (w/ washer; M4x8; white).



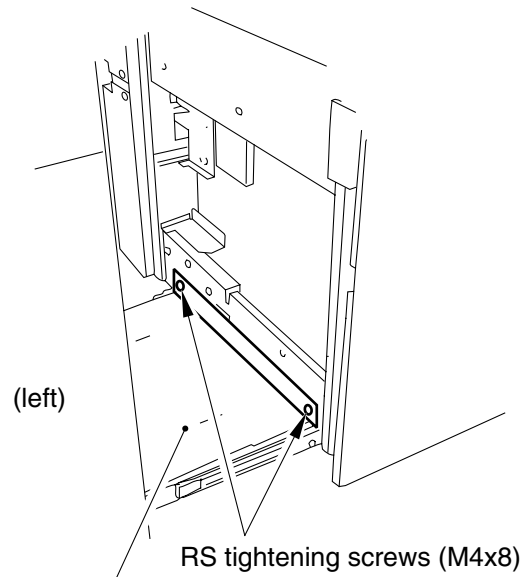
**Figure 6b-1**

- c. If the Side Paper Deck-M1 is already installed, Remove the deck temporarily from the deck mount.
- 1) Disconnect the connector of the deck from the copier's back.



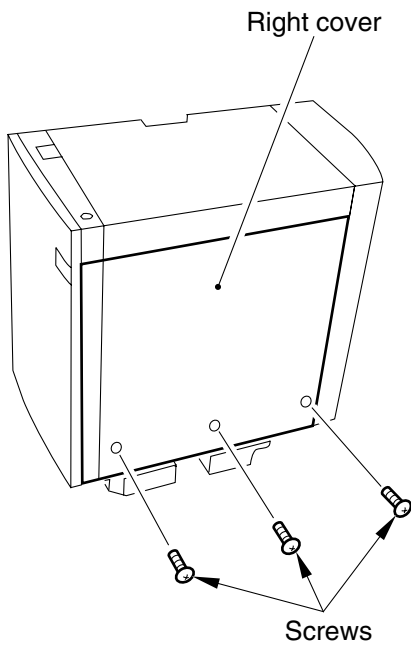
**Figure 6c-1**

- 3) Remove the four screws used to secure the deck in place to the deck mount.

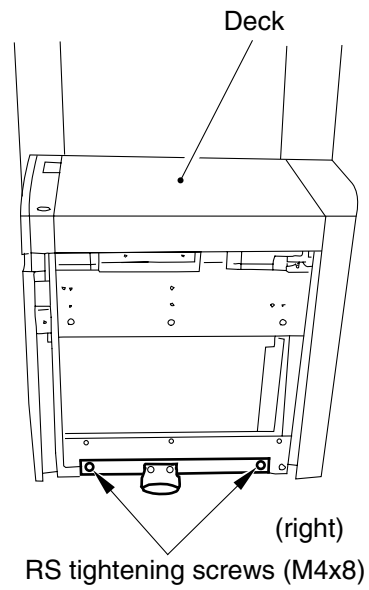


**Figure 6c-3**

- 2) Remove the three screws, and remove the right cover of the deck.



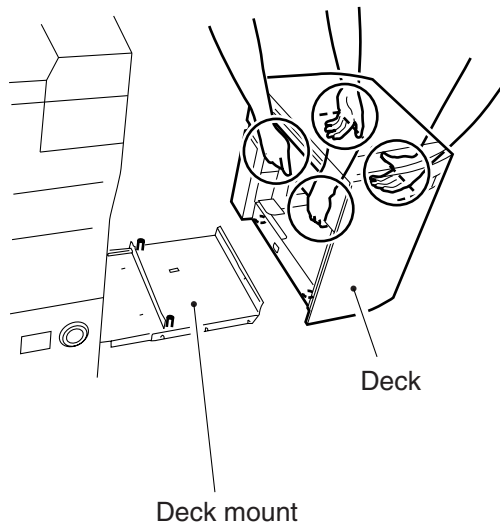
**Figure 6c-2**



**Figure 6c-4**

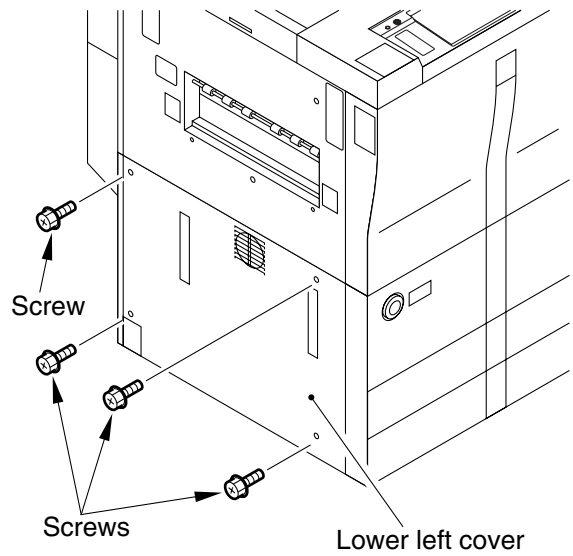


- 4) Holding the deck as shown in the figure, lift the deck off the deck mount.



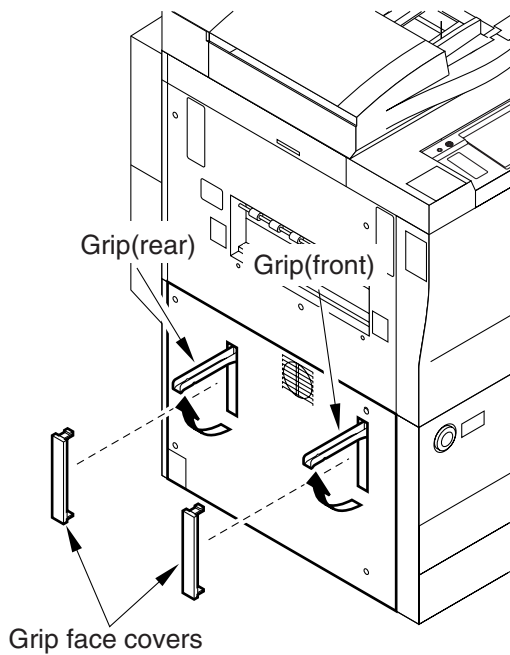
**Figure 6c-5**

- 6) Remove the four screws, and detach the copier's lower left cover.



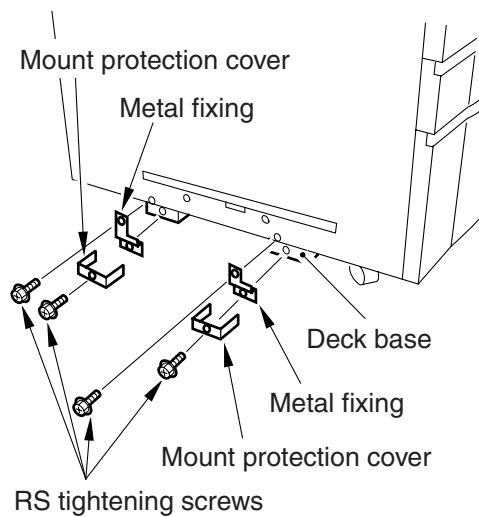
**Figure 6c-7**

- 5) Remove the grip face covers (front, rear), and shift up the front and rear grips as shown.



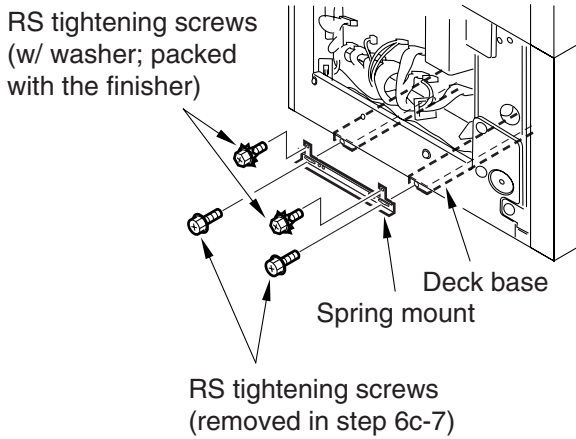
**Figure 6c-6**

- 7) Remove the four screws, and detach the two mount protection covers the two metal fixings. (You will not be using the mount protection covers and the metal fixings; however, you will be using two of the removed screws.)



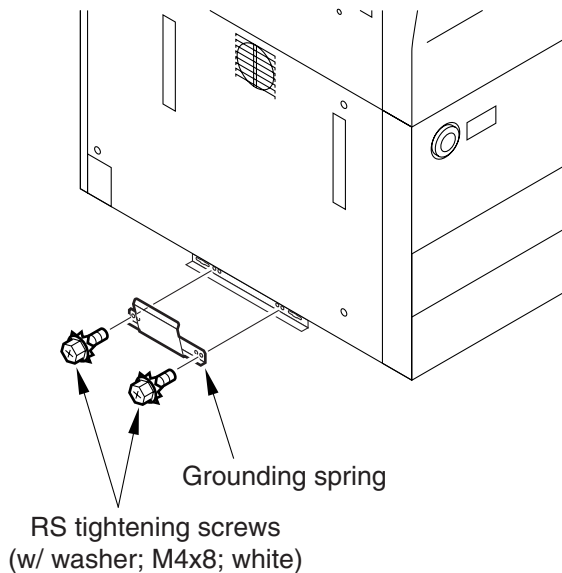
**Figure 6c-8**

- 8) Secure one end of the spring mount to the deck base with two RS tightening screws (removed in step 6c-7.)
- 9) Mount the other end (upper hole) of the spring mount to the copier's lower left cross member with RS tightening screws (w/ washer; M4x8; white; packed with the finisher).



**Figure 6c-9**

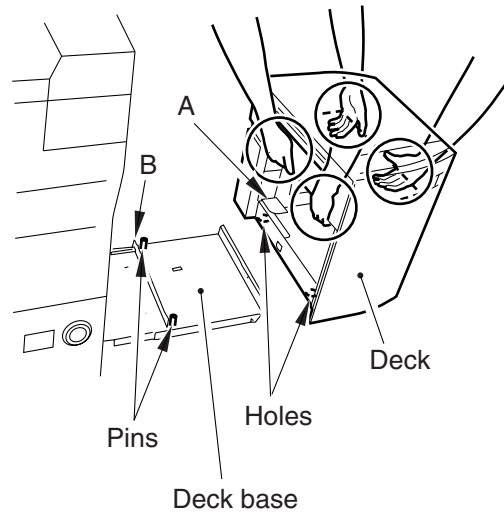
- 10) Mount the copier's lower left cover and the grip face covers with four screws.
- 11) Mount the grounding spring to the spring mount with the binding screw (w/ washer; M4x8; white; packed with the finisher).



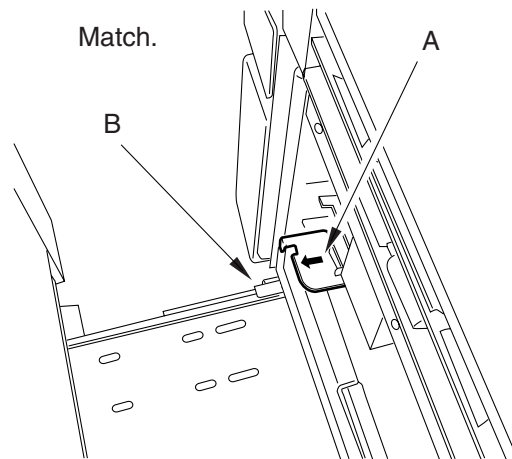
**Figure 6c-10**

- 12) Holding the deck as shown in the figure, place the deck on the deck base while matching the holes in the bottom of the deck and the pins of the deck mount.

At this time, try to match the arrow (A) of the deck lower left cross member and the edge of the deck base (B) to facilitate the work.

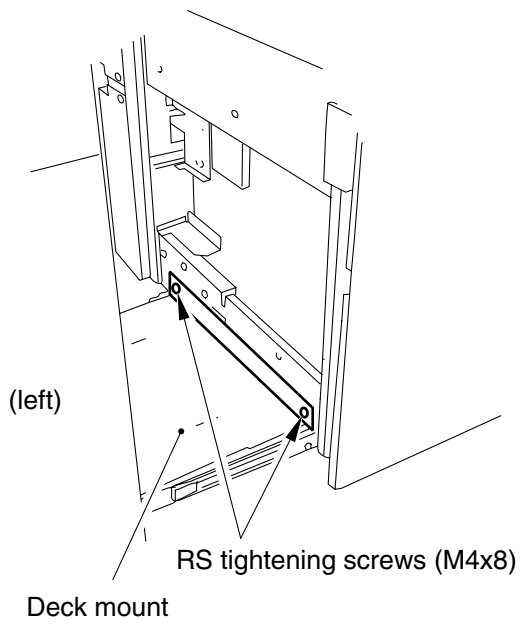


**Figure 6c-11**



**Figure 6c-12**

13) Secure the deck in place to the deck base with four RS tightening screws (M4x8).

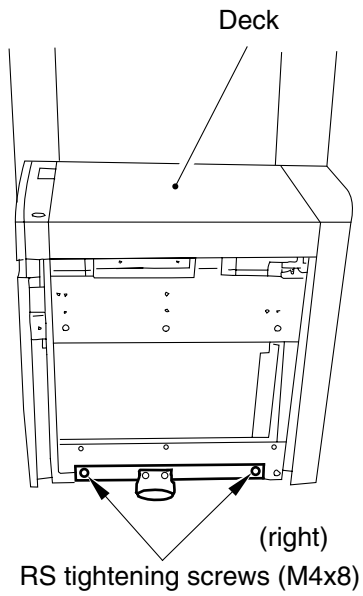


14) Mount the right cover of the deck with the three screws removed in step 6c-2.

15) Slide the deck to the left to set it to the copier.

16) Connect the connector of the deck to the copier's back.

**Figure 6c-13**



**Figure 6c-14**

## 7

## Attaching the Upper Cover Spacer

Attach the upper cover spacer to the right side of the upper cover.

- 1) Peel off the backing paper from the back of the upper cover spacer.
- 2) Attach the upper cover spacer to the right side of the upper cover. Be sure that the top edge of the upper cover spacer is found between the matte surface and the gloss surface of the upper cover.

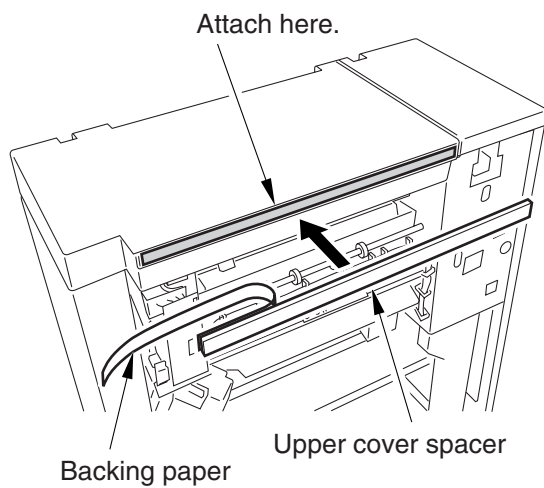


Figure 7-1

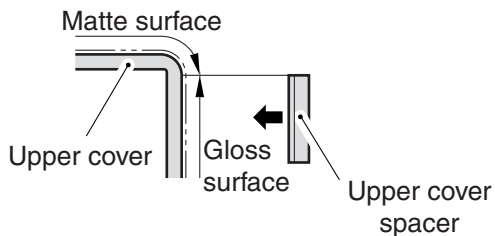


Figure 7-2

## 8

## Adjusting the Height/Slope

After connecting the finisher to the copier temporarily, adjust the height/slope of the finisher.

## A. Connecting to the Copier

- 1) Open the front cover and the upper cover.
- 2) Detach the inside cover (Four RS tightening screws (M4x10; white), you will be using removed screws).

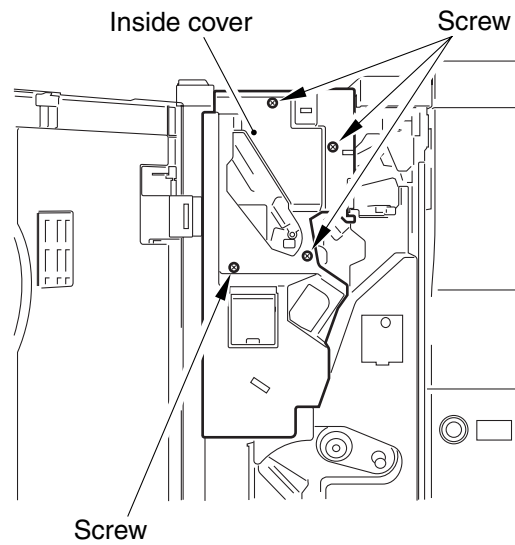


Figure 8A-1

- 3) Remove the two screws, and remove the finisher's upper rear cover.

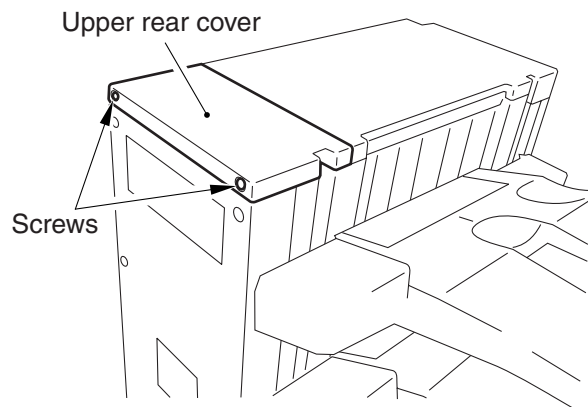
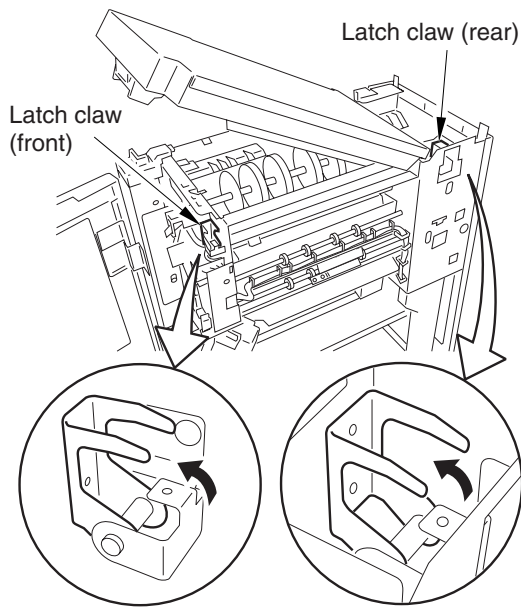


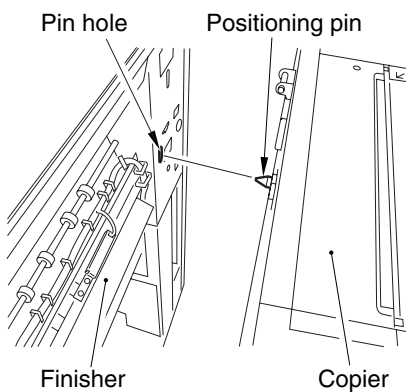
Figure 8A-2

- 4) Shift up the finisher's latch claw (front, rear).



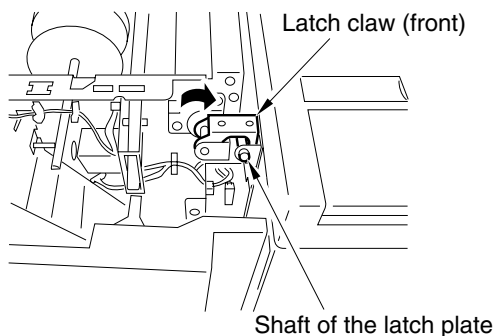
**Figure 8A-3**

- 5) While matching the finisher's pin hole and the copier's positioning pin, connect the finisher to the copier.

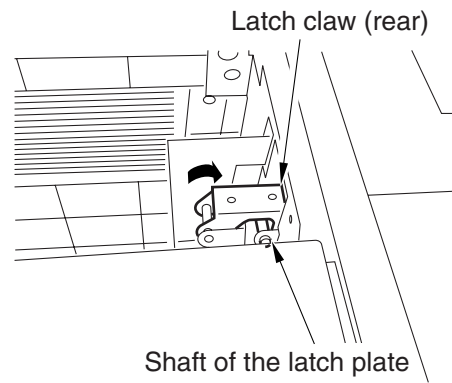


**Figure 8A-4**

- 6) Shift down the finisher's latches (front, rear) to engage them with the shafts of the latch plates.

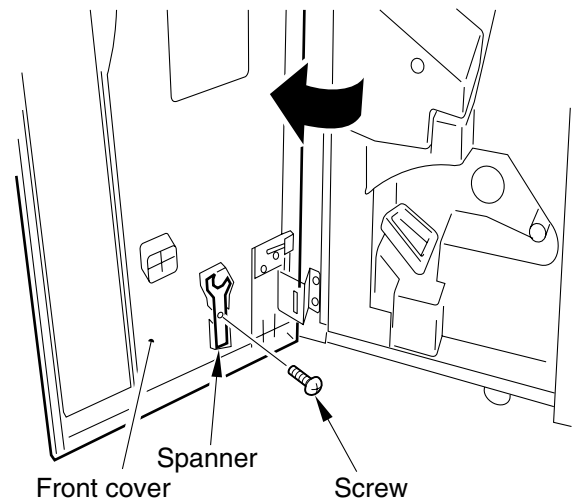


**Figure 8A-5a**



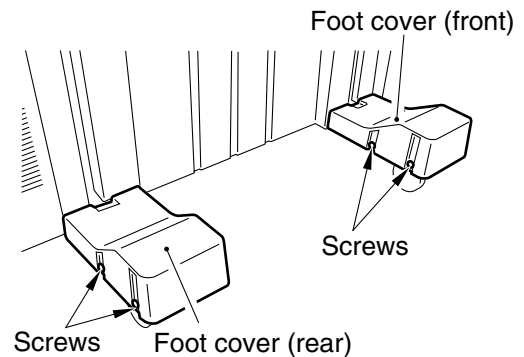
**Figure 8A-5b**

- 7) Open the finisher's front cover. Then, remove the screw, and remove the spanner from behind the front cover.



**Figure 8A-6**

- 8) Remove the two screws each, and remove the finisher's foot covers (front, rear).



**Figure 8A-7**

## B. Adjusting the Height

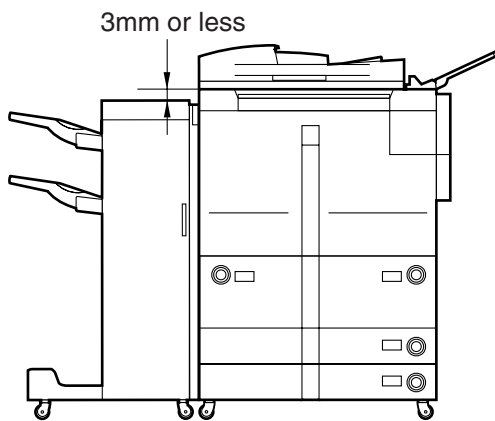
Depending on the floor, the finisher may not be even with the copier. Adjust its height as necessary.

### 8B-1. Checking the Height

1) Compare the top surface of the finisher's upper cover and the top surface of the copier's left cover, and find out whether the difference is within the indicated range. If not, adjust the height; otherwise, go to step 8c.

a. If the Top Surface of the Copier's Left Cover is Higher

→3 mm or less

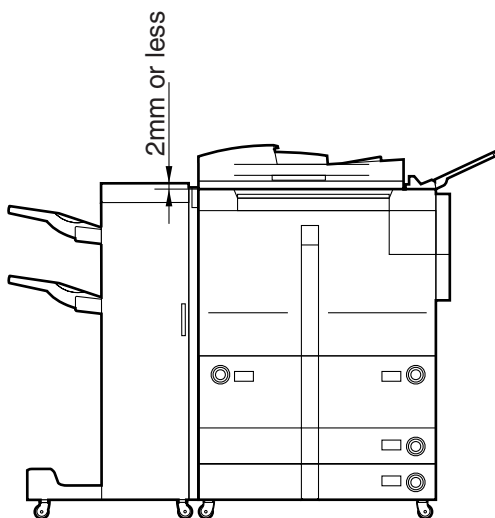


If not as indicated, perform step 8b-2.

**Figure 8B-1a**

b. If the Top Surface of the Finisher's Upper Cover Is Higher

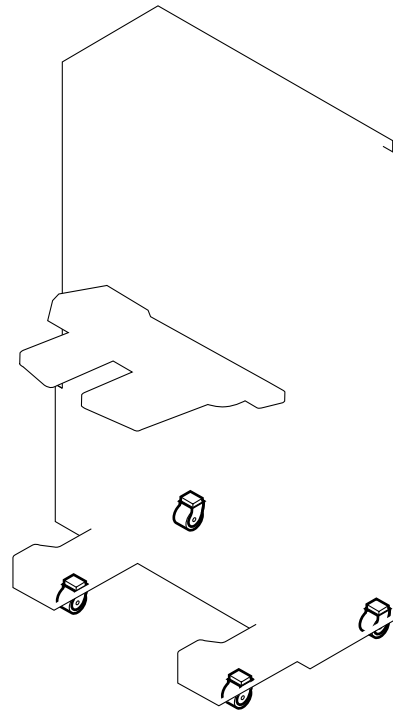
→2 mm or less



If not as indicated, go to step 8b-3.

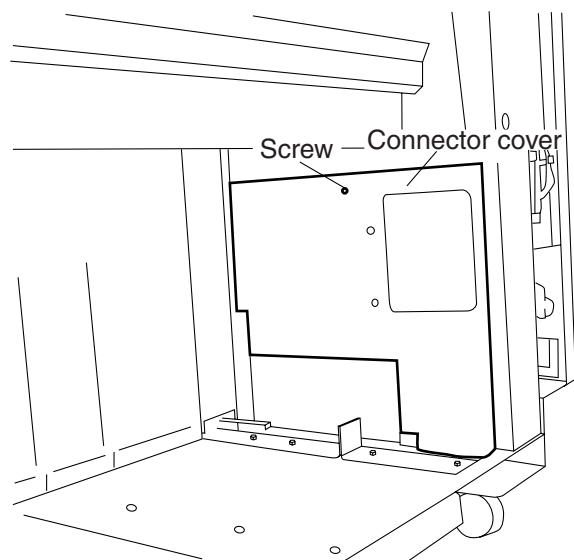
**Figure 8B-1b**

2) Release the finisher from the copier. Turn the four casters shown in Figure 8b-2 to make adjustments.



**Figure 8B-2**

3) When adjusting the rear left side caster, remove the connector cover (one screw).



**Figure 8B-3**

8B-2.If the Top Surface of the Copier's Left Cover Is Higher

- 1) As needed, turn the fixing nut in the direction of arrow C to loosen. Turn the caster adjusting foot in the direction of arrow D.

A full turn of the adjusting foot will change the height by about 1.75 mm. Compute the number of turns needed, and make as many turns as necessary for each of the four feet.

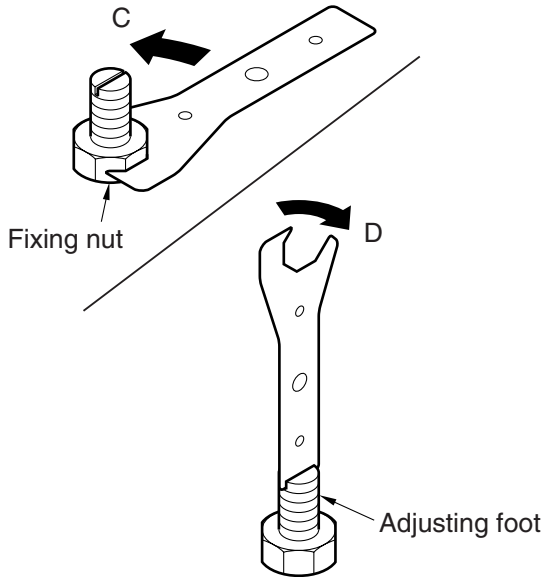


Figure 8B-4

8B-3.If the Top Surface of the Finisher's Upper Cover is Higher

- 1) As needed, turn the fixing nut in the direction of arrow C to loosen. Turn the caster adjusting foot in the direction of arrow E.

A full turn of the adjusting foot will change the height by about 1.75 mm. Compute the number of turns needed, and make as many turns as necessary for each of the four feet.

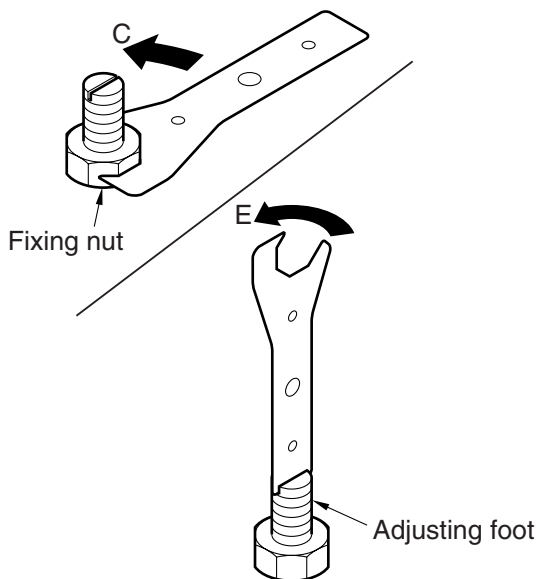


Figure 8B-5

8B-4.Checking the Height

- 1) Connect the finisher to the copier temporarily once again, and check the height. If the difference is within the indicated range, go to the next step; otherwise, make adjustments once again.

C.Correcting the Tilt

Correct the tilt of the finisher to keep it level.

8C-1 Checking the Tilt

- 1) Connect the finisher to the copier temporarily.
- 2) Measure the gap between the finisher and the copier at the bottom.

\* The gap must be  $5 \pm 0.3$  mm (standard). if it is larger (tilt A), go to step 8C-2; if it is smaller (tilt B), go to step 8C-3.

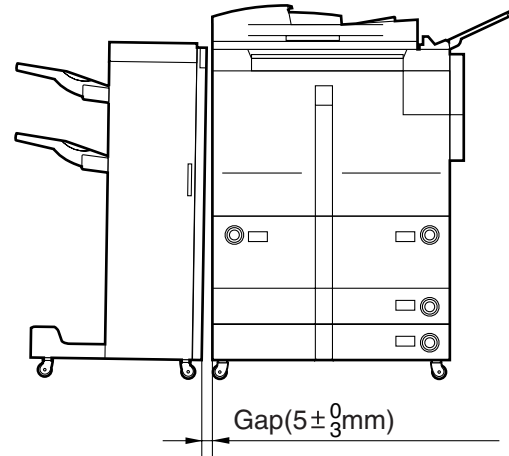


Figure 8C-1

Note:

To correct the tilt, turn the two casters shown in Figure 8C-2.

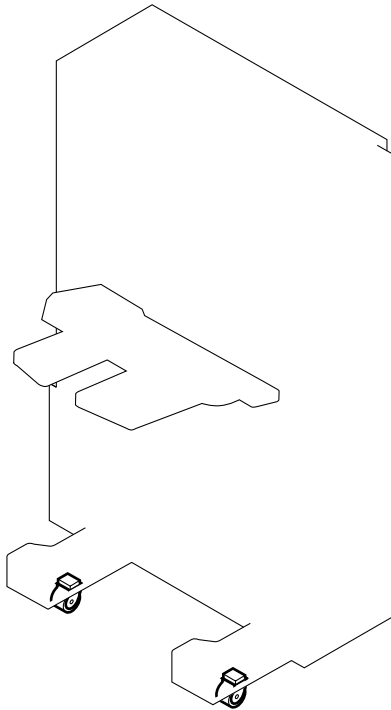


Figure 8C-2

#### 8C-2 Correcting Tilt A

- 1) Loosen the fixing nut by turning it in the direction of arrow C.

Turn the caster adjusting foot as much as needed in the direction of arrow D. Perform the same for both front and rear feet.

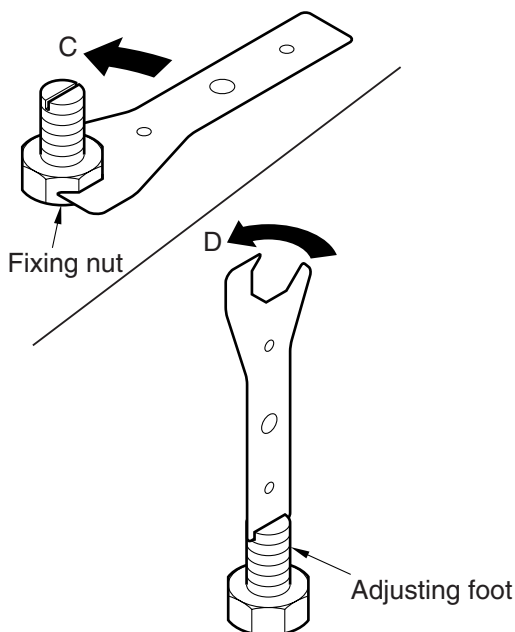


Figure 8C-3

- 2) Check the gap between the finisher and the copier. If the gap is still large, turn the adjusting foot as necessary; otherwise, turn it in reverse. Perform the same for both front and rear feet.

#### 8C-3 Correcting Tilt B

- 1) Loosen the fixing nut by turning it in the direction of arrow C.

Turn the caster adjusting foot as much as needed in the direction of arrow E. Perform the same for both front and rear feet.

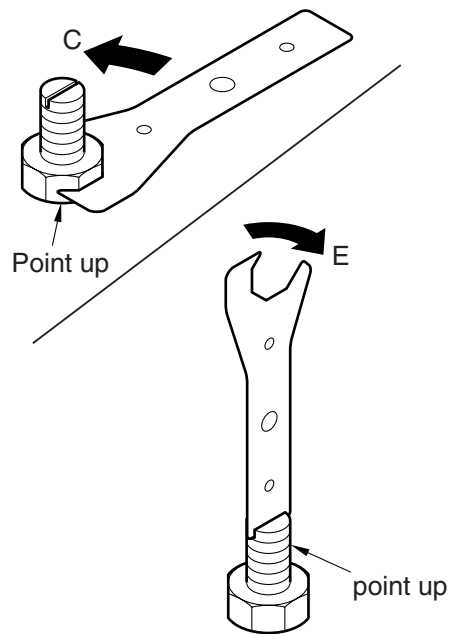


Figure 8C-4

- 2) Check the gap between the finisher and the copier. If the gap is still small, turn the adjusting foot as necessary; otherwise, turn it in reverse. Perform the same for both front and rear feet.

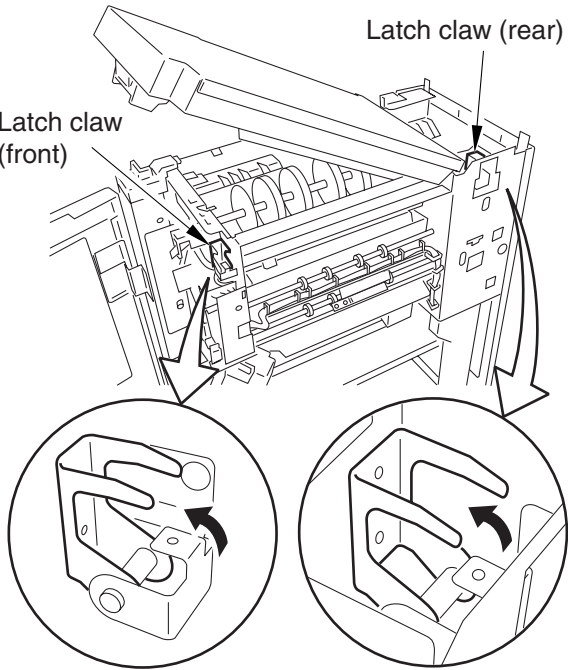
#### 8C-4. Securing the Nut

- 1) Check the height of the finisher. If it is not appropriate, adjust the slope once again.
- 2) Release the finisher from the copier, and tighten the fixing nut of all casters.
- 3) Fit the foot covers (front, rear) with two screws each.
- 4) Mount the spanner to the front cover with a screw.



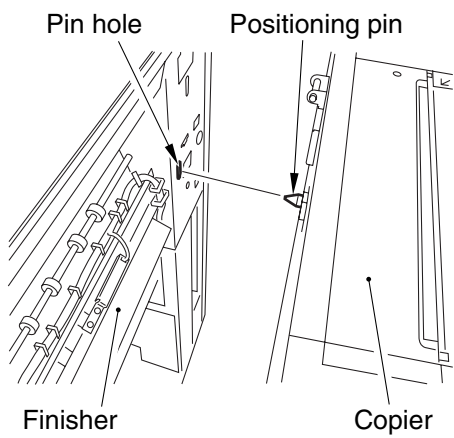
<b>9</b>	<b>Connecting to the Copier</b>
----------	---------------------------------

- 1) Attach the connector cover (one screw), if any.
- 2) Shift up the finisher's latch claws (front, rear). Or, check to make sure that they are up.



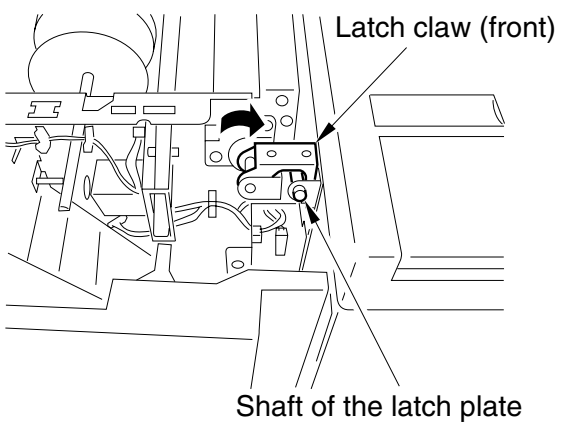
**Figure 9-1**

- 3) While matching the finisher's pin hole and the copier's positioning pin, connect the finisher to the copier.



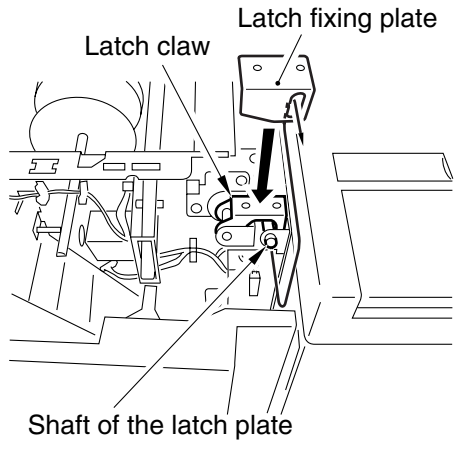
**Figure 9-2**

- 4) Shift down the finisher's latch claw (front), and engage it with the shaft of the latch plate.



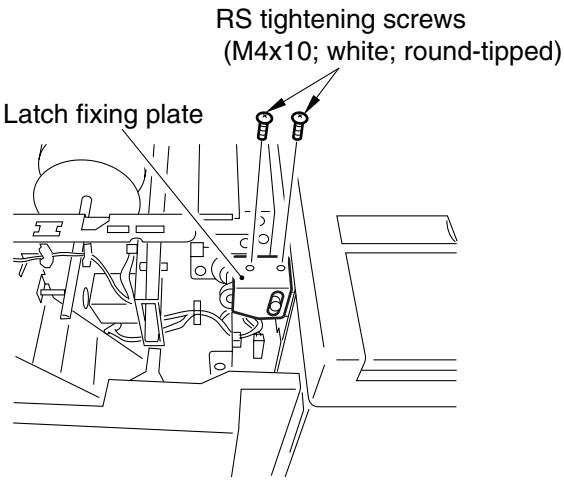
**Figure 9-3**

- 5) Put the latch fixing plate over the latch plate (front).



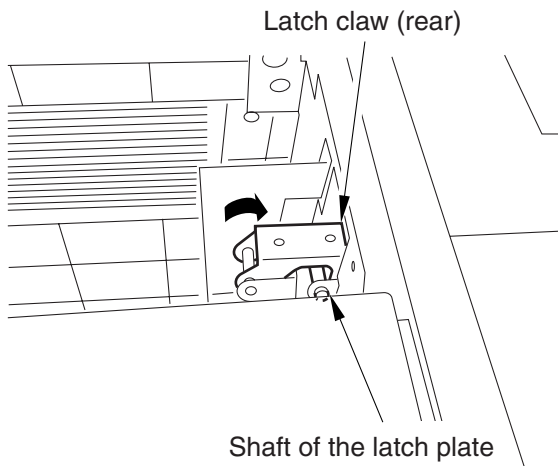
**Figure 9-4**

- 6) Secure the latch fixing plate with two RS tightening screws (M4x10; white; round-tipped).



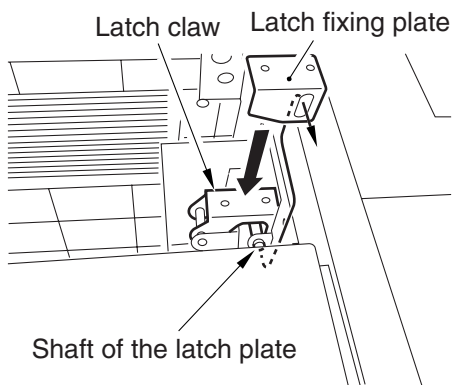
**Figure 9-5**

- Shift down the finisher's latch claw (rear), and engage it with the shaft of the latch plate.



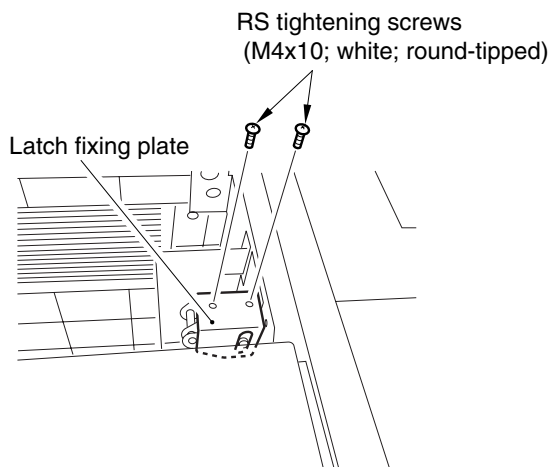
**Figure 9-6**

- Put the latch fixing plate over the latch claw (rear).



**Figure 9-7**

- Secure the latch fixing plate with two RS tightening screws (M4x10; white; round-tipped).

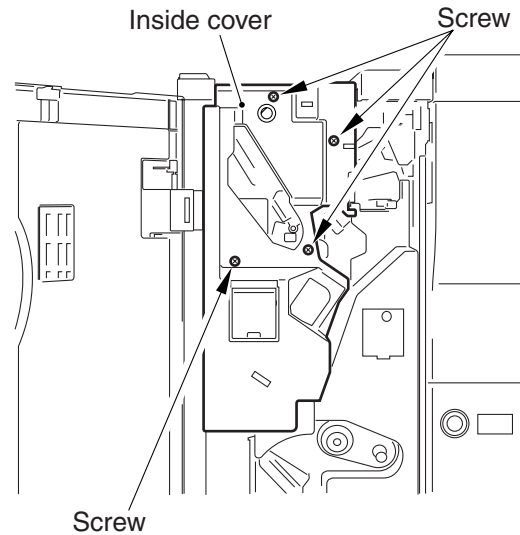


**Figure 9-8**

- Mount the finisher's upper rear cover with two screws.


<b>10</b>	<b>Mounting the Inside Cover and the Labels</b>
-----------	---

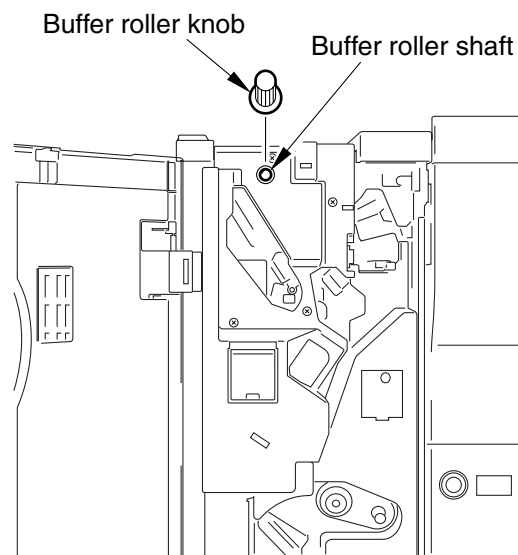
- Mount the inside cover to the front side plate behind the finisher's front cover with four RS tightening screws (M4x10; white).



**Figure 10-1**

- Fit the buffer roller knob with the buffer roller shaft on the inside cover.

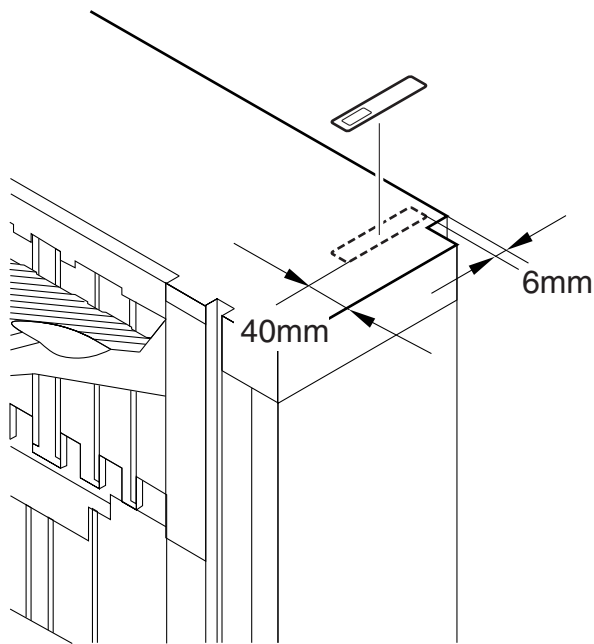
**Caution:**  Be sure to push in the knob until it stops.



**Figure 10-2**

**A. Paper turning label**

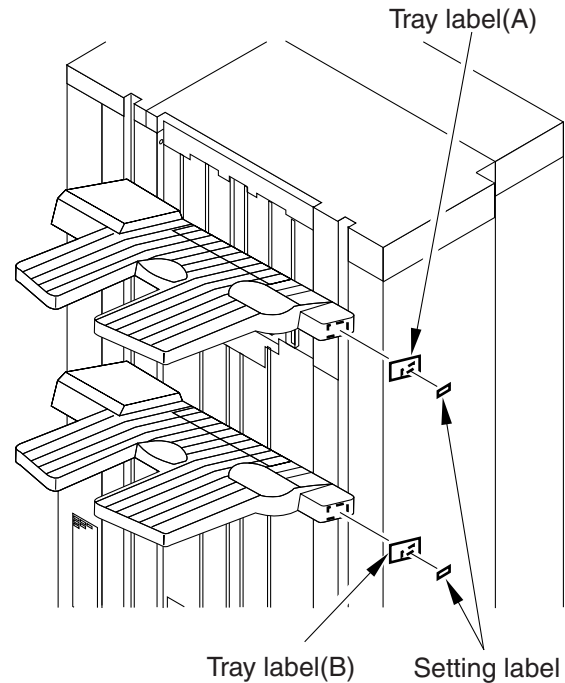
- 1) Put the label indicating turning paper over on the top of the front right side of the upper cover. (select the desired label from one of the six languages.)



**Figure 10-3**

**C. Tray labels/ setting labels**

- 1) Attach the labels for trays A/B in the positions shown in the diagram.
- 2) Within the tray label frame, attach the setting label according to the user's preferences.

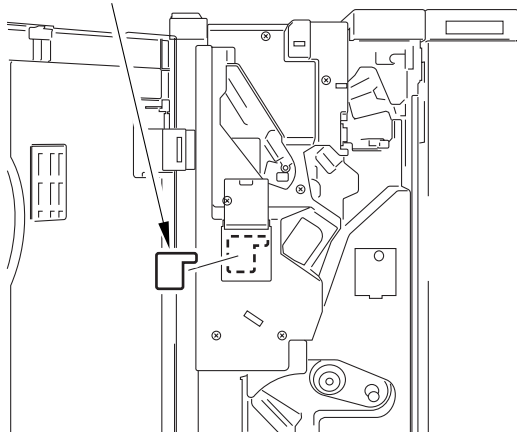


**Figure 10-5**

**B. Module separation label**

- 1) Open the finisher front cover.
- 2) Open the switch cover and attach the module separation label. (There is a label positioning guide.)

**Module separation label**



**Figure 10-4**

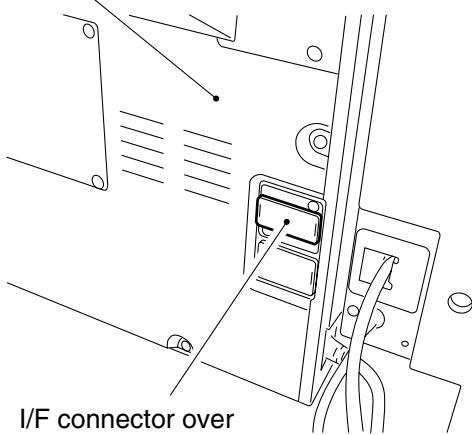
## 11 Connecting the I/F Cable and the Power Cable

### Caution:

⚠ When connecting the I/F cable and the power cable, be sure to turn off the copier and disconnect the copier's power cable from the outlet.

- 1) Remove the I/F connector cover from the copier's back, making the copier ready for connection of the I/F connector.

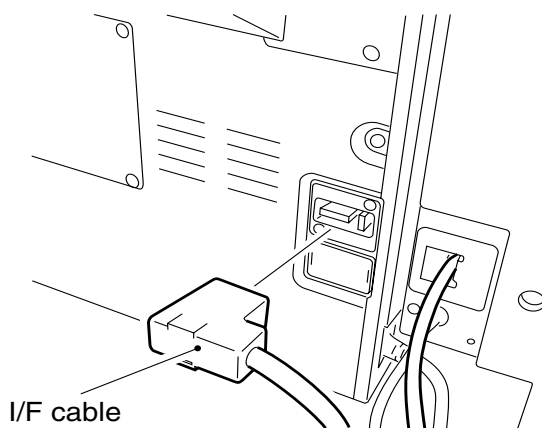
Back of the copier



I/F connector over

Figure 11-1

- 2) Connect the finisher's I/F cable to the copier's I/F connector.

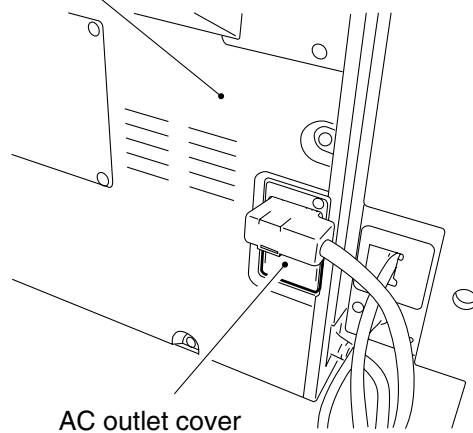


I/F cable

Figure 11-2

- 3) Remove the AC outlet cover from the copier's back, making the copier ready for connection to an AC outlet.

Back of the copier

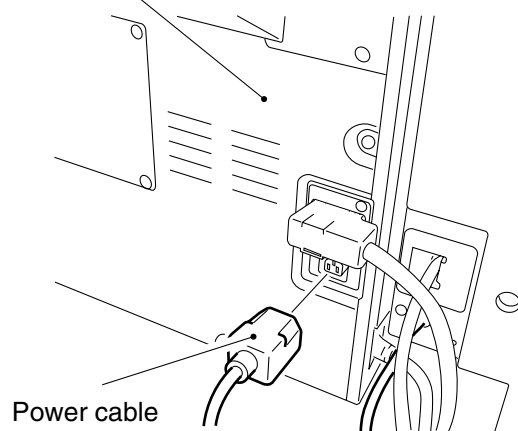


AC outlet cover

Figure 11-3

- 4) Connect the finisher's power cable to the copier's AC outlet.

Back of the copier



Power cable

Figure 11-4